



# MRVS<sup>II</sup>

DC Inverter Unit with Front Discharge

# MRV S II - FEATURES

## IMPROVED CONFIGURATION AND PERFORMANCE (8/10/12HP SIDE DISCHARGE)

Flexible applications with bigger outdoor capacity options.

### High efficiency DC fan motor

- DC fan motor with stepless inverter control, increases efficiency by 45% comparing with AC motor.

### Larger fan diameter

- Ø570mm larger axial flow fan
- Zigzag design, reduces disturbance in airflow as well as increasing air volume and reducing noise level.

### High efficiency condenser

- Newly designed high efficiency inner grooved tube.
- New hydrophilic corrugated fissurefin increases efficiency.



### Vector inverter control

- 180 degrees sine wave vector control, 64-bit operation
- Precision control achieves high efficiency and lower noise levels

### Double pressure sensor

- Equipped with high and low voltage pressure sensors
- Accurate pressure control ensures the system runs smoothly, increasing energy efficiency.

### Twin rotary DC Inverter compressor

- High chamber DC inverter twin rotary compressor
- Increased energy efficiency by achieving smaller vibrations and benefiting from lower sound levels.

## LEADING TECHNOLOGY (4-6HP)

Two-stage super cooling cycle technology, increases efficiency by 9%. (Double fan) 30°C maximum temperature in cooling increases unit refrigerating capacity by 46%



## INCREASING POWERFUL HEATING CAPACITY

When the ambient temperature is low, the heat exchange capability of the outdoor unit is decreased and the amount of air returned by the compressor is reduced. By increasing the refrigerant flow during the heating cycle of the indoor unit heat exchanger, we improve the heating capacity.

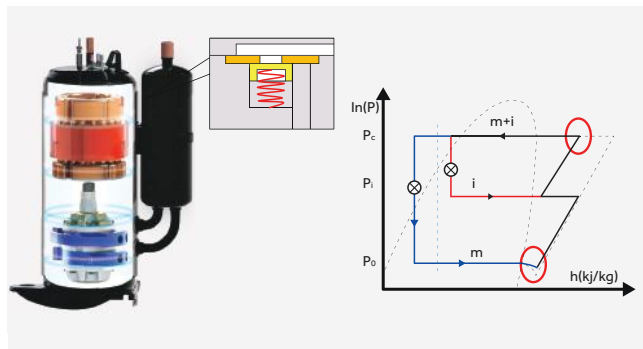

# MRV S II - FEATURES

## HIGH EER AND COP(8/10/12HP)

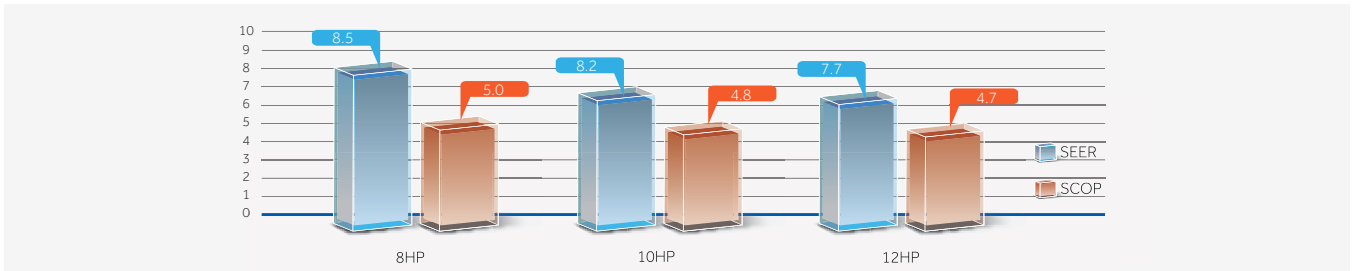

## DC FAN AND FAN MOTOR

- DC inverter fan motor is highly efficient during part load operation
- 16-stage speed control; high efficiency operation especially in low speed

- 45% increase in efficiency compared with AC motor due to reduced input power
- 570mm diameter fan, increases air flow and achieves higher efficiency(8/10/12HP)

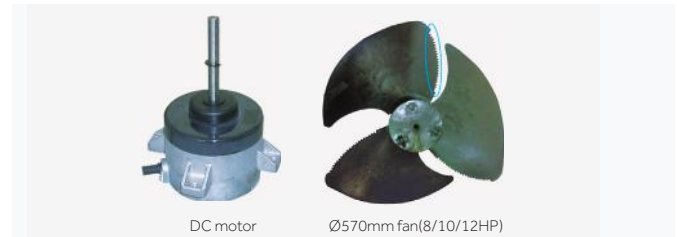
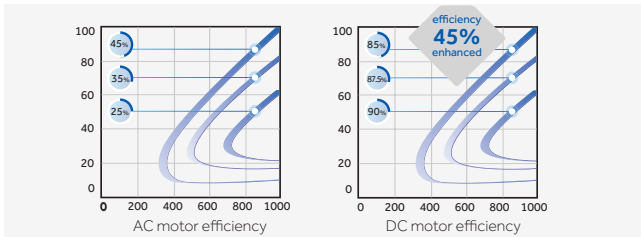

## SELF-CLEANING FUNCTION ON INDOOR AND OUTDOOR UNITS

During operation, dirt accumulates on the evaporator. If the evaporator is not cleaned regularly, accumulated dirt reduces the thermal exchange by 15-30% and also promotes the proliferation of bacteria and mould.

The new Self Clean technology is the first of its kind to integrate the self-cleaning function of both the evaporator and the condenser. It starts with cleaning the evaporator, then switches to cleaning the condenser without stopping the compressor.

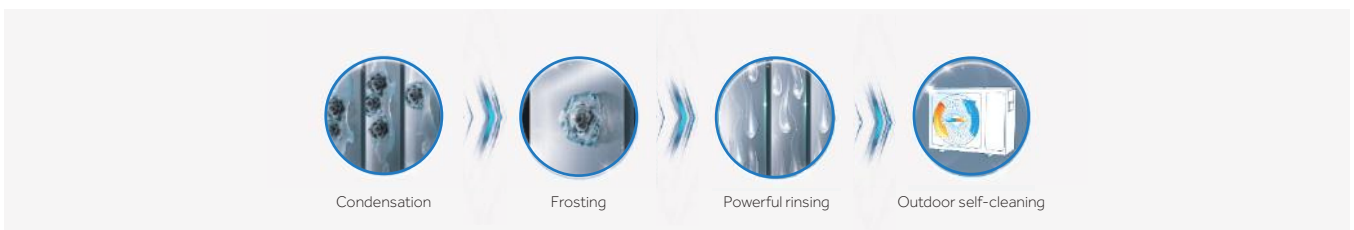

## LOW NOISE LEVEL

- Night quiet operation function
- Noise levels can be reduced down to 45dB(A)

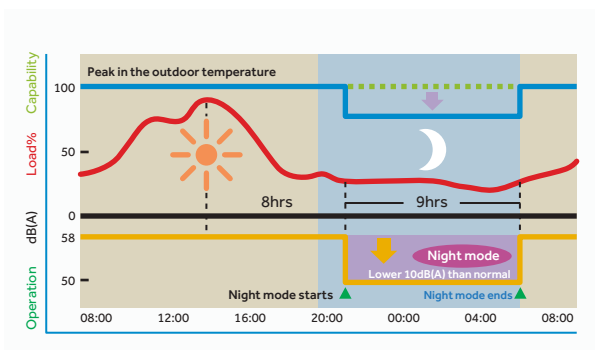

## NEW DC INVERTER TWIN ROTARY COMPRESSOR

- A small torque change and a good dynamic balance of the system allows the unit to run smoothly with little vibration, low noise levels and increased efficiency
- Increased efficiency during part load operation

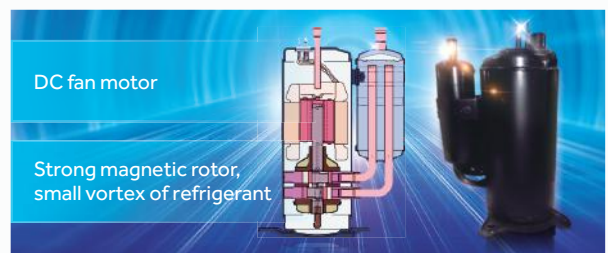

## MRV S II - FEATURES

- 1 New aerodynamic fan  
550mm super big diameter aerospace helix fan. lowering sound level by 3dB(A)
- 2 Enlarged air inlet path and spiral air outlet path.  
Air flow direction follows the grill direction which reduces sound levels by 2-4 dB(A)
- 3 Automatic sound reduction capability. Night mode set by the PCB is 8dB(A) lower

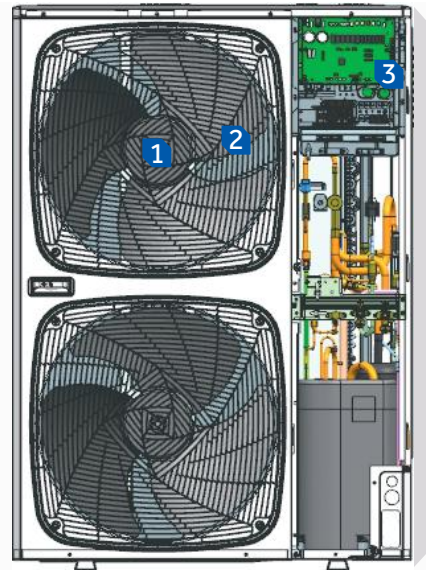

### LOW SOUND OPERATION

- DC inverter compressor achieves a smoother operation and effectively reduces sound levels by eliminating the frequent start up of the compressor.
- Precision control achieved by vector inverter control
- Non-resonance motor brackets are used on the DC fan motor which ensures a smoother operation of the motor and reduces operating sound levels
- Larger fan diameter inspired by aviation design principles for quieter operation



### COMPACT SIDE DISCHARGE DESIGN

Side discharge design eliminates the need for additional ventilation hood compared with a top discharge unit, ideal for narrow spaces.



# MRV S II - FEATURES

## LONG PIPE LENGTH, INCREASED HEIGHT DROP

- Total pipe length: 300m
- Single pipe length: Max.175m
- From outdoor to the first branch pipe: 135m
- From the first branch to the furthest indoor door unit: 40m
- Height drop: 50m( outdoor above)/40m (outdoor below)
- Height drop between indoor units: 15m



## PARAMETER DISPLAY PANEL

The parameter display panel has been improved by moving it to the side of the unit. The parameter can be easily accessed by directly opening the protective cover for maintenance.

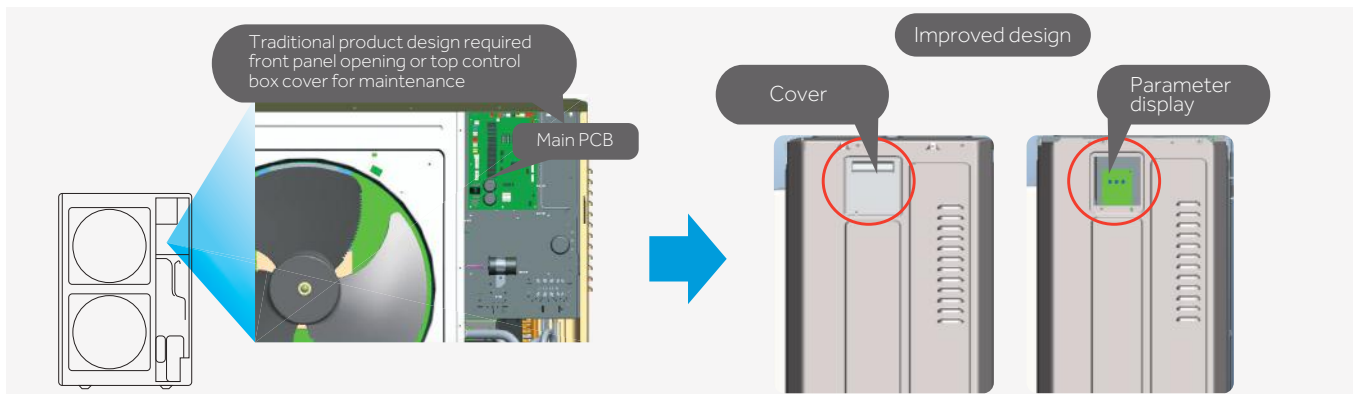

## AUTOMATIC REFRIGERANT RECLAIM TECHNOLOGY

Set automatic refrigerant reclaim through the dip switch. The refrigerant in the indoor unit can be automatically returned to the outdoor unit. This is convenient during maintenance, reducing refrigerant waste, maintenance cost and time.

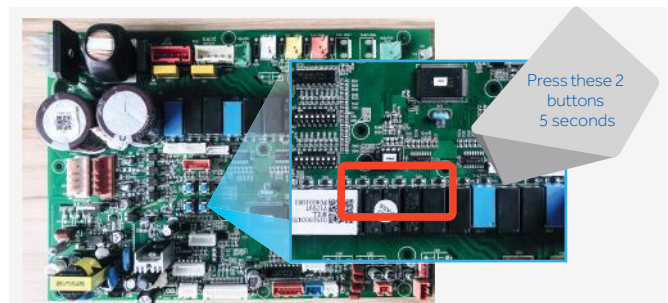

## REFRIGERANT CONTROL TECHNOLOGY

Refrigerant control technology without high pressure accumulator, reduces the refrigerant volume and enhances operating efficiency.

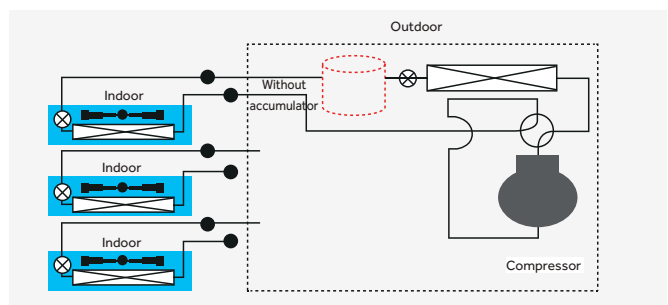

## HIGH AND LOW DOUBLE PRESSURE SENSOR

- Double pressure sensor with PID control technology.
- Combining high speed communication to quick start the compressor with more precise control the temperature can be controlled with a precision of  $\pm 0.5^{\circ}\text{C}$ .

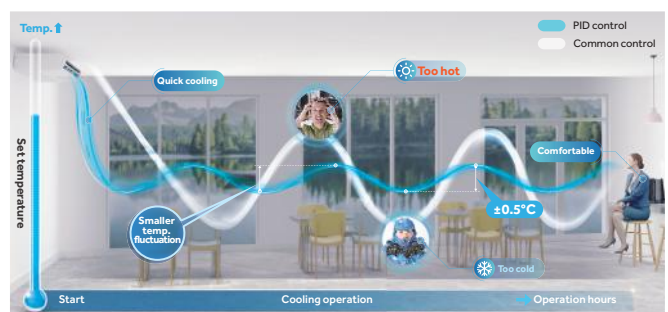

## Outdoor Units with Frontal Discharge MRV S II



### 4-5HP

AU042FNERA

AU052FNERA

Model			AU042FNERA	AU052FNERA
Capacity <sup>[1]</sup>	Power Class	HP	4	5
	Cooling	kW	12,10	14,00
	Heating	kW	12,10	14,00
Electrical parameters	Power supply	Ph/V/Hz	1/220-240/50/60	1/220-240/50/60
	Absorbed power - Cooling	kW	4,25	5,00
	Max absorbed current - Cooling	kA	28,30	29,30
	Absorbed power - Heating	kW	4,10	4,83
	Max absorbed current - Heating	kA	27,90	29,30
	EER energy class	/	2,85	2,80
	COP energy class	/	2,95	2,90
	SEER energy class (T1)	/	4,90	4,85
	SCOP energy class (T1)	/	3,50	3,55
	η <sub>s,hs,c</sub> %	%	193	191
η <sub>s,hs,h</sub> %	%	137	139	
Fan	Air flow (High)	m <sup>3</sup> /h	5400	5400
Pressure sound level	Sound pressure level (Cooling)	dB(A)	58	60
	Sound pressure level (Heating)	dB(A)	60	62
Dimensions	Unit Dimensions WxDxH	mm	950x370x965	950x370x965
	Packaged unit dimensions WxDxH	mm	1010x458x990	1010x458x990
Weight	Net/Shipping weight	kg	90/102	90/102
Compressor	Compressor type	/	Rotary Inverter	Rotary Inverter
	Motor Power	W	4130	4130
	Compressor quantity	/	1	1
Refrigerant	Refrigerant type	/	R410A	R410A
	Pre-charged refrigerant qty.	kg	3,30	3,30
Piping	Ø Liquid side refrigerant pipe	mm (inch)	9,52 (3/8)	9,52 (3/8)
	Ø Gas side refrigerant pipe	mm (inch)	15,88 (5/8)	15,88 (5/8)
	Maximum piping length	m	120	120
	Max linear piping length (Equivalent/Real)	m	70/60	70/60
	Std. drop between IU and OU	m	30/20	30/20
	Max. drop between IU *3	m	10	10
Connection ratio	Indoor / Outdoor Capacity Ratio	%	50-130	50-130
	Maximum number of connectable IUs	/	7	8
Working temp.	Cooling	°C	-5-50	-5-50
	Heating	°C	-15-21	-15-21

(\*) The specifications indicated are obtained with the following test conditions: in Cooling mode, Indoor temperature of 27°C WB / 19°C DB and Outdoor temperature of 35°C WB / 24°C DB. In Heating mode, Indoor temperature of 20°C WB and Outdoor temperature of 7°C WB / 6°C DB

# Outdoor Units with Frontal Discharge

## MRV S II



### 4-6HP

AU042FPERA

AU052FPERA

AU062FPERA

AU041FPERA

AU051FPERA

AU061FPERA

Model			AU042FPERA	AU052FPERA	AU062FPERA	AU041FPERA	AU051FPERA	AU061FPERA
Capacity <sup>[1]</sup>	Power Class	HP	4	5	6	4	5	6
	Cooling	kW	12,10	14,00	15,50	12,10	14,00	15,50
	Heating	kW	12,10	14,00	15,50	12,10	14,00	15,50
Electrical parameters	Power supply	Ph/V/Hz	1/220-240/50/60	1/220-240/50/60	1/220-240/50/60	3/380-415/50/60	3/380-415/50/60	3/380-415/50/60
	Absorbed power - Cooling	kW	3,61	4,33	5,17	3,61	4,33	5,17
	Max absorbed current - Cooling	A	34,10	35,50	36,90	11,40	11,90	12,90
	Absorbed power - Heating	kW	3,23	3,76	5,00	3,23	3,76	5,00
	Max absorbed current - Heating	A	32,70	34,10	35,50	10,90	11,40	11,90
	EER energy class	/	3,35	3,23	3,00	3,35	3,23	3,00
	COP energy class	/	3,75	3,72	3,10	3,75	3,72	3,10
	SEER energy class (T1)	/	6,82	6,65	6,80	6,82	6,65	6,80
	SCOP energy class (T1)	/	4,05	4,11	4,05	4,05	4,11	4,05
	ηs,h %	%	270	263	269	270	263	269
ηs,h %	%	159	161	159	159	161	159	
Fan	Air flow (High)	m <sup>3</sup> /h	7200	7200	7200	7200	7200	7200
Pressure sound level	Sound pressure level (Cooling)	dB(A)	57	58	59	57	58	59
	Sound pressure level (Heating)	dB(A)	57	58	59	57	58	59
Dimensions	Unit Dimensions WxDxH	mm	950x370x1350	950x370x1350	950x370x1350	950x370x1350	950x370x1350	950x370x1350
	Packaged unit dimensions WxDxH	mm	1023x471x1420	1023x471x1420	1023x471x1420	1023x471x1420	1023x471x1420	1023x471x1420
Weight	Net/Shipping weight	kg	108/123	108/123	108/123	108/123	108/123	108/123
	Compressor type	/	Rotary Inverter	Rotary Inverter	Rotary Inverter	Rotary Inverter	Rotary Inverter	Rotary Inverter
Compressor	Motor Power	W	4130	4130	4130	4060	4060	4060
	Compressor quantity	/	1	1	1	1	1	1
Refrigerant	Refrigerant type	/	R410A	R410A	R410A	R410A	R410A	R410A
	Pre-charged refrigerant qty.	kg	4,00	4,00	4,00	4,00	4,00	4,00
Piping	Ø Liquid side refrigerant pipe	mm (inch)	9,52 (3/8)	9,52 (3/8)	9,52 (3/8)	9,52 (3/8)	9,52 (3/8)	9,52 (3/8)
	Ø Gas side refrigerant pipe	mm (inch)	15,88 (5/8)	15,88 (5/8)	15,88 (5/8)	15,88 (5/8)	15,88 (5/8)	15,88 (5/8)
	Maximum piping length	m	300	300	300	300	300	300
	Max linear piping length (Equivalent/Real)	m	175/150	175/150	175/150	175/150	175/150	175/150
	Std. drop between IU and OU	m	50	50	50	50	50	50
	Max. drop between IU *3	m	15	15	15	15	15	15
Connection ratio	Indoor / Outdoor Capacity Ratio	%	50-130	50-130	50-130	50-130	50-130	50-130
	Maximum number of connectable IUs	/	8	10	13	8	10	13
Working temp.	Cooling	°C	-5-50	-5-50	-5-50	-5-50	-5-50	-5-50
	Heating	°C	-20-27	-20-27	-20-27	-20-27	-20-27	-20-27

(\*) The specifications indicated are obtained with the following test conditions: in Cooling mode, Indoor temperature of 27°C WB / 19°C DB and Outdoor temperature of 35°C WB / 24°C DB. In Heating mode, Indoor temperature of 20°C WB and Outdoor temperature of 7°C WB / 6°C DB

(a) With solder reduced from 22,22 to 19,05 for connecting the pipe to the unit valve accessory accompanying the product.

(b) The unit also works regularly with 9,52 diameter pipe. Requires 9,52>12,7 adapter to connect to the machine (not provided by Haier).

## Outdoor Units with Frontal Discharge MRV S II



### 8-12HP

AU08NFKERA  
AU10NFKERA  
AU12NFKERA

Model			AU08NFKERA	AU10NFKERA	AU12NFKERA
Capacity <sup>[1]</sup>	Power Class	HP	8	10	12
	Cooling	kW	22,60	28,00	31,50
	Heating	kW	22,60	30,50	31,50
Electrical parameters	Power supply	Ph/V/Hz	3/380-415/50/60	3/380-415/50/60	3/380-415/50/60
	Absorbed power - Cooling	kW	6,95	8,67	11,52
	Max absorbed current - Cooling	A	19,00	23,80	25,40
	Absorbed power - Heating	kW	5,79	8,03	8,49
	Max absorbed current - Heating	A	18,00	22,60	24,20
	EER energy class	/	3,25	3,23	2,73
	COP energy class	/	3,90	3,80	3,71
	SEER energy class (T1)	/	7,67	7,65	7,47
	SCOP energy class (T1)	/	4,05	4,16	4,21
	η <sub>s,h</sub> %	%	304	303	296
	η <sub>s,h</sub> %	%	159	163	165
Fan	Air flow (High)	m <sup>3</sup> /h	10000	10000	10000
Pressure sound level	Sound pressure level (Cooling)	dB(A)	63	64	65
	Sound pressure level (Heating)	dB(A)	65	66	67
Dimensions	Unit Dimensions WxDxH	mm	1050x400x1636	1050x400x1636	1050x400x1636
	Packaged unit dimensions WxDxH	mm	1150x510x1790	1150x510x1790	1150x510x1790
Weight	Net/Shipping weight	kg	149/168	149/168	149/168
Compressor	Compressor type	/	Twin Rotary Inverter	Twin Rotary Inverter	Twin Rotary Inverter
	Motor Power	W	6270	6270	6270
	Compressor quantity	/	1	1	1
Refrigerant	Refrigerant type	/	R410A	R410A	R410A
	Pre-charged refrigerant qty.	kg	5,10	5,10	5,10
Piping	Ø Liquid side refrigerant pipe	mm (inch)	9,52 (3/8)	9,52 (3/8)	9,52 (3/8)
	Ø Gas side refrigerant pipe	mm (inch)	19,05 (3/4)	22,22 (7/8)	25,40 (1)
	MaMaximum piping length	m	300	300	300
	Max linear piping length (Equivalent/Real)	m	175/150	175/150	175/150
	Std. drop between IU and OU	m	50	50	50
	StMax. drop between IU *3	m	15	15	15
Connection ratio	Indoor / Outdoor Capacity Ratio	%	50-130	50-130	50-130
	Maximum number of connectable IUs	/	13	16	19
Working temp.	Cooling	°C	-5~48	-5~48	-5~48
	Heating	°C	-20~27	-20~27	-20~27

(\*) The specifications indicated are obtained with the following test conditions: in Cooling mode, Indoor temperature of 27°C WB / 19°C DB and Outdoor temperature of 35°C WB / 24°C DB. In Heating mode, Indoor temperature of 20°C WB and Outdoor temperature of 7°C WB / 6°C DB



# Outdoor Units with Frontal Discharge MRV S II

AU042FNERA AU052FNERA

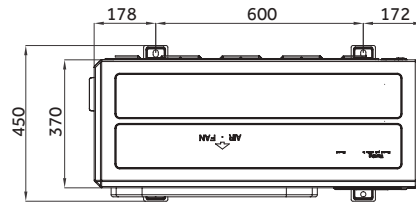
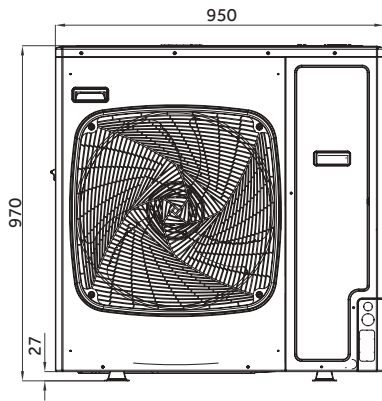

AU042FPERA AU052FPERA AU062FPERA AU04IFPERA AU05IFPERA AU06IFPERA

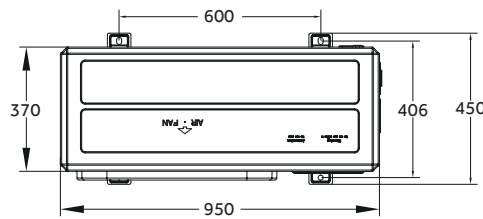
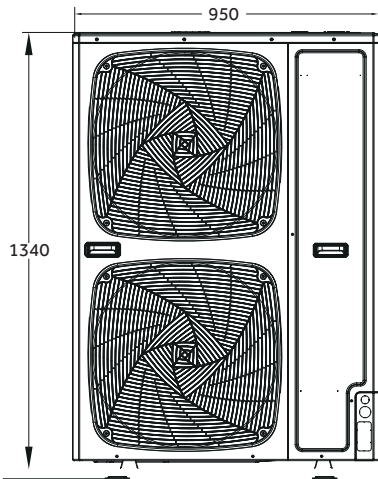

AU08NFKERA AU10NFKERA AU12NFKERA

